



# Shoe Sorter

---

## EXECUTIVE SUMMARY

Maximize productivity with high-efficiency sortation that isn't a hassle to maintain. Our shoe sorter has all-electric diverts for small or large products that operates smoothly and quietly. Gain productivity from minimal downtime with quick-release slats, drop-out switches and a UHMW slat surface for easy cleaning.

## OVERVIEW

- Capable of speeds up to 650 feet per minute and throughput rates reaching 18,000 cases per hour
- Ideal for high-volume sortation of varying sized products
- High speed electric servo divert switch – All electric (non-pneumatic)
- Avoid crashes with dedicated divert control processor
- UHMW slat surface for low friction, easy cleaning
- Maintenance-friendly, easy drop-out divert switch, removable side covers, open frame design, and quick-change slat makes it easy to replace slats and shoes
- Integrated PLC controlled automatic chain oiling system

MOTOR  
**5 – 50 HP**

SHOE DISTANCE  
**5”**

RATE  
**Up to 18,000 CPH**

Standard Conveyor Overall Width		24"   30"
Motor	5 - 50 HP. high efficiency integral gearmotor	
Speeds	up to 650 FPM, product dependent	
Rate	up to 18,000 cartons per hour	
Shoe Distance	5" center-to-center	
Product Load Capacity	Max 100lb/ft, max 50lb per slat	
Minimum Case Size	5" x 7"	
Slat & Chain Support	Ultra low friction urethane tire ball bearings	

**APPLICATIONS**

- Works with a variety of product sizes and types
- Great for sorting fragile products such as cases of glass containers

**ADDITIONAL EQUIPMENT**

- Floor Supports
- Guide Rails
- Spurs (Gravity & Powered)
- Infeed Knife Edge Induction Belt (AC & DC)
- Controls & Integration

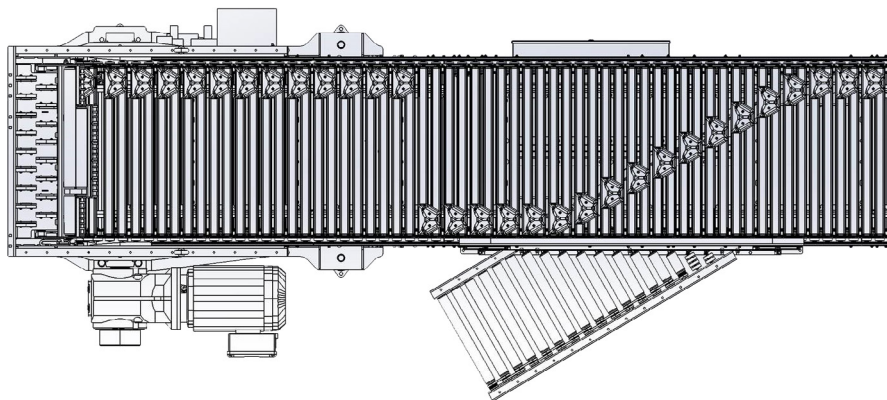
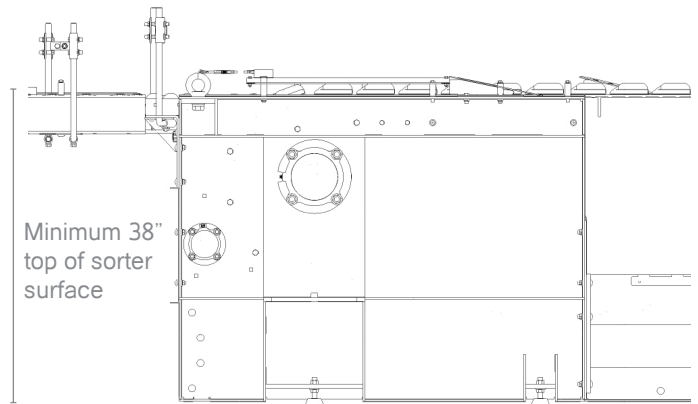

"A" Effective Sorter Width
21"
33"

"B" Sorter Overall Width
36"
48"

Warranty: One Year (Please see our warranty for further details)

All information and calculations in the General Guidelines table are based on typical applications.

Please contact Bastian Solutions for other lengths, widths, and configurations.